

Installation

- a) refer to page 3 to check the jumper positions for your required function, i.e. for upside down use.
- b) connect the power supply and the motor unit to the remote receiver. 2 different plug sizes make this connection only possible to make in the right way
- c) after having connected the plugs, the blue light will be lit
- d) push the emitter buttons and the motor unit will move up and down
- e) for stopping the motion one of the buttons need to be pushed again

Learning

- a) if the remote receiver does not respond when pushing the emitter buttons, reset the receiver. After that, code the emitter and receiver together again.
- b) in perfect conditions it is possible to code up to 10 remote emitters to the remote receiver but reliability of all lifts operating can be affected by things such as battery condition and interference from other RF equipment, therefore a maximum of 4-6 lifts is suggested depending upon the importance of this features reliability.

Coding of RF emitter

- a) push the learner button on the receiver for less than 1 sec.
- b) push one of the emitter buttons
- c) the red light will start flashing and afterwards turn off
- d) the units now are coded together with a unique code

Coding of IR emitter (optional, need purchase of IR kit)

- a) push the learner button on the receiver for less than 1 sec.
- b) push one of the emitter buttons
- c) the red light will start flashing and afterwards turn off
- d) the units now are coded together with a unique code

Reset

- a) push and hold down the learner button on the receiver for 10 sec. (will be reset when the red light start to blink). Now follow the learner process to recode the emitter.

External rocker switch

- a) this should always be fitted somewhere accessible in case the RF handset or battery fails.

Trouble shooting

- a) all testing should be done using the rocker switch. If just the emitter is not working then follow the learner instructions and also try a new battery, the tiny LED light on the emitter does not indicate that battery condition is sufficient. The learner process must be followed after the battery is replaced. Occasionally on a brand new emitter the battery may be weak due to battery manufacturing.
- b) check all plug connections, especially check that the receiver sockets in the white plug connections have not been pushed back.
- c) if you can hear the relays in the RF box clicking and the blue light is on then power is reaching the RF receiver, when you press and hold the rocker then the red light on the receiver should come on. If this is happening but no movement then it is likely that no power is reaching the lift from the output connection. Alternatively there is a problem inside the lift.
- d) see www.venset.com click "support" if contacting VenSet you will need a photo of the CE label from the lift and details of when and where the lift was purchased.

Battery change

Change of battery in RF emitter, type 27A/12V / IR emitter, type CR2016 3V

- a) remove the three screws on back side
- b) remove the lid on back side
- c) lift up old battery. In case of a leaking battery wear protection gloves.
- d) place new battery with positive polarity pointing to the mark VCC on the PCB.
- e) place lid on back side and tighten the three screws

Do not deposit used batteries with the household waste use special waste collection facilities for used batteries.



RF emitter

IR emitter

Feature functions and settings – only for A lifts!

Several features are controlled by using Jumpers. A Jumper is either **set** or **open**. See example below.

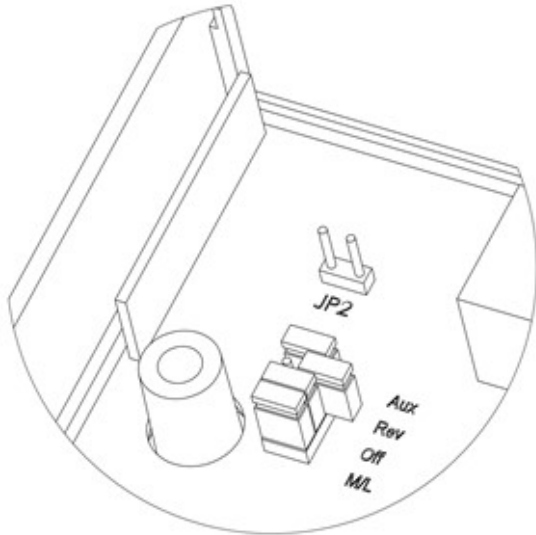

Example of Jumper setting, see picture:

Jumper Aux = set
Jumper Rev = open
Jumper Off = set
Jumper M/L = set

Default Jumper setting is:.

Jumper Aux = set
Jumper Rev = set
Jumper Off = set
Jumper M/L = set

A. Orientation of TV-Lift

The **Jumper Rev** is default = **set**, for TV-Lifts mounted upside up. For upside down the **Jumper Rev** has to be moved to **open**.

B. Anti-squeeze on/off (autostop with auto reverse)

The **Jumper Off** is default = **set**, which means that the anti-squeeze function is off. Move the **Jumper Off** to the **JP2** pins to activate the function.

C. Remote emitter function

The **Jumper M/L** is default = **set** and the buttons on the emitter only need to be pushed once for operation. If moved to **open** then the emitter button will need to be held down during the operation of the lift, ie..for use where a higher level of safety may be required.