

Synchro Control System – 7XPOWM



Instructions concerning:

ConSet Column lifts – Model no. 501-X1 / 501-23 / 501-19

VENSET TV-Lift – Model no. TS700C

VENSET TV-Lift – Model no. TS1000C

For the synchronization of 2 and 3 lifts.

(All lifts must have the same model number)

501-X1 / 501-23 / 501-19

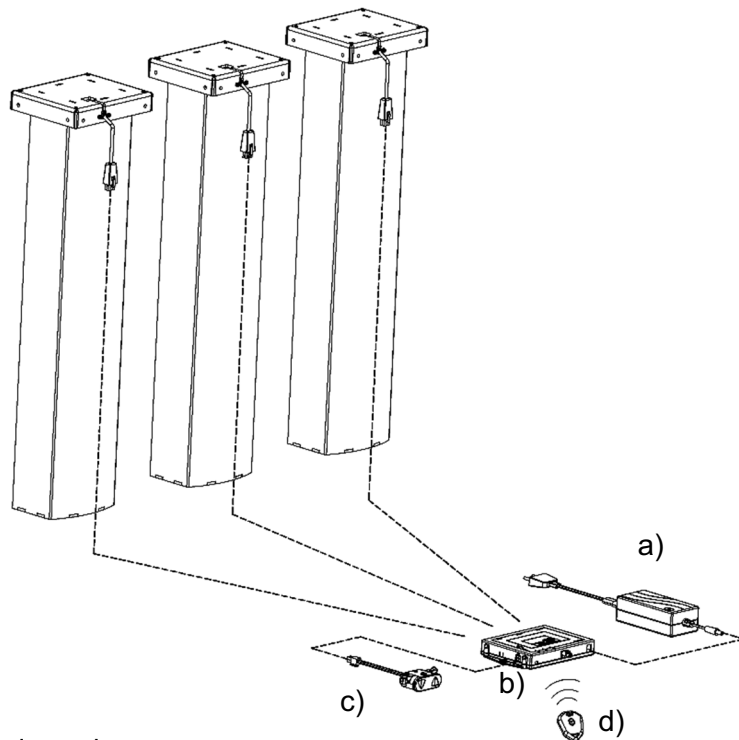

Parts included

- a) 1 x PSU with mains wire.
- b) 1 x MASTER box.
- c) 1 x Manual up/down control panel.
- d) 1 x RF remote emitter optional.

TS700C / TS1000C

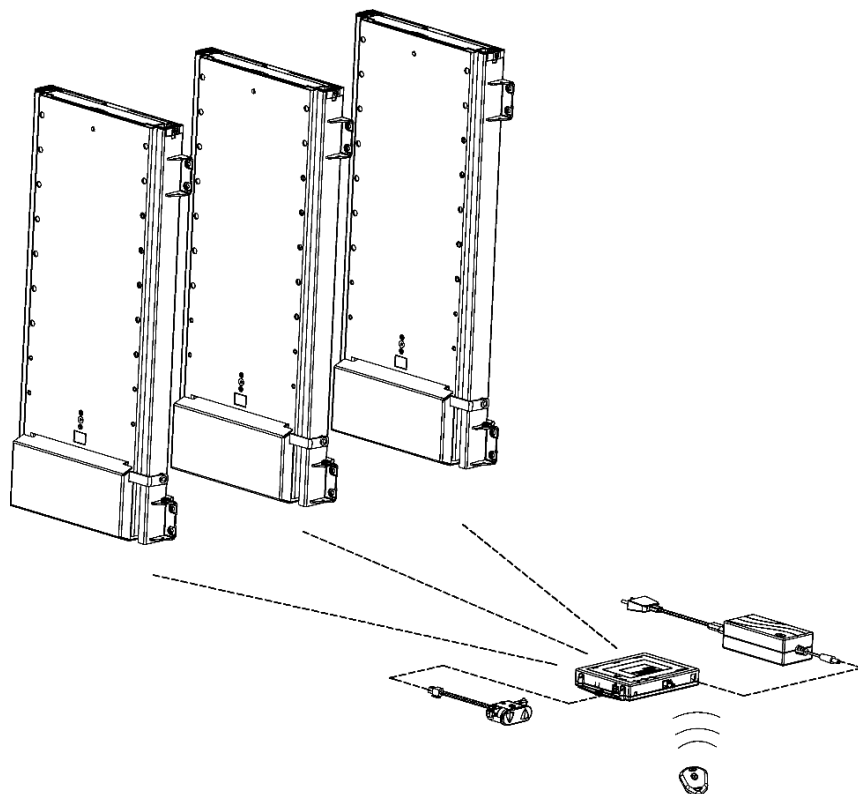

IMPORTANT

You must configure the MASTER box for your model.

FEATURES

MASTER Box:

- Electronically adjustable end stop – top and bottom.
- Soft start and soft stop.
- Constant speed loaded and unloaded.
- Upside-down mode.
- Automatic duty cycle protection.
- Automatic impact overload protection.

RF Remote:

- 1 to 5 handsets can be coded.
- Latching, one press operation mode (see warnings).
- Non latching, hold button operation mode.

WARNINGS

- Never connect a mixture of models on one 7XPOWM.
- Always perform synchronization if you change the configuration e.g. if you remove 1 lift.
- If 2 or more lifts are physically linked ie.by a TV screen then the RF remote must only be used in non-latching mode.
- The lifts and this synchronization system are sold as components so the final product manufacturer or installer is responsible for decisions concerning their suitability of use.
- The RF handset should not be used for a height adjustable desk application.

INSTALLATION

First set the MASTER box mode - refer to page 3 for instructions.

Synchronization:

Before using the system the lifts must be synchronized.

Note: Do not connect to the mains supply until after all the other connections 1-4 are made. Then you are ready to perform the synchronization.

Each lift must be at it's lowest position - press and hold the down button of the control panel until all the lifts are at the bottom position and the

How to connect

1. Connect the lifts to the MASTER box.
2. Connect the manual control panel to the MASTER box.
3. Connect the PSU to the MASTER box.
4. Connect the PSU's to a mains supply.
5. Perform synchronisation as above.

SETTING THE MASTER BOX MODE

The default settings are for ConSet Column lifts – Model no. 501-X1 / 501-23 / 501-19 as upright 'upside up' i.e. for a height adjustable desk leg set.

If you are using this product with Venset TV lift - Model no. TS1000C or TS700C then you must change the 'model mode' settings inside the MASTER box. You will also need to change the 'upside mode' if you are using the lifts upside down.

Open the MASTER box by removing the small screws.

MODEL MODE:

Column lifts – Dip switch no. 1 = set as 'OFF'.

TV-Lift – Dip switch no. 1 = set as 'ON'.

UPSIDE MODE:

Upside up – Dip switch no. 3 = set as 'OFF' (default).

Upside down – Dip switch no. 3 = set as 'ON'.

When closing the MASTER box be careful that the circuit board is in position, close the cover and lightly tighten the 4 small screws.

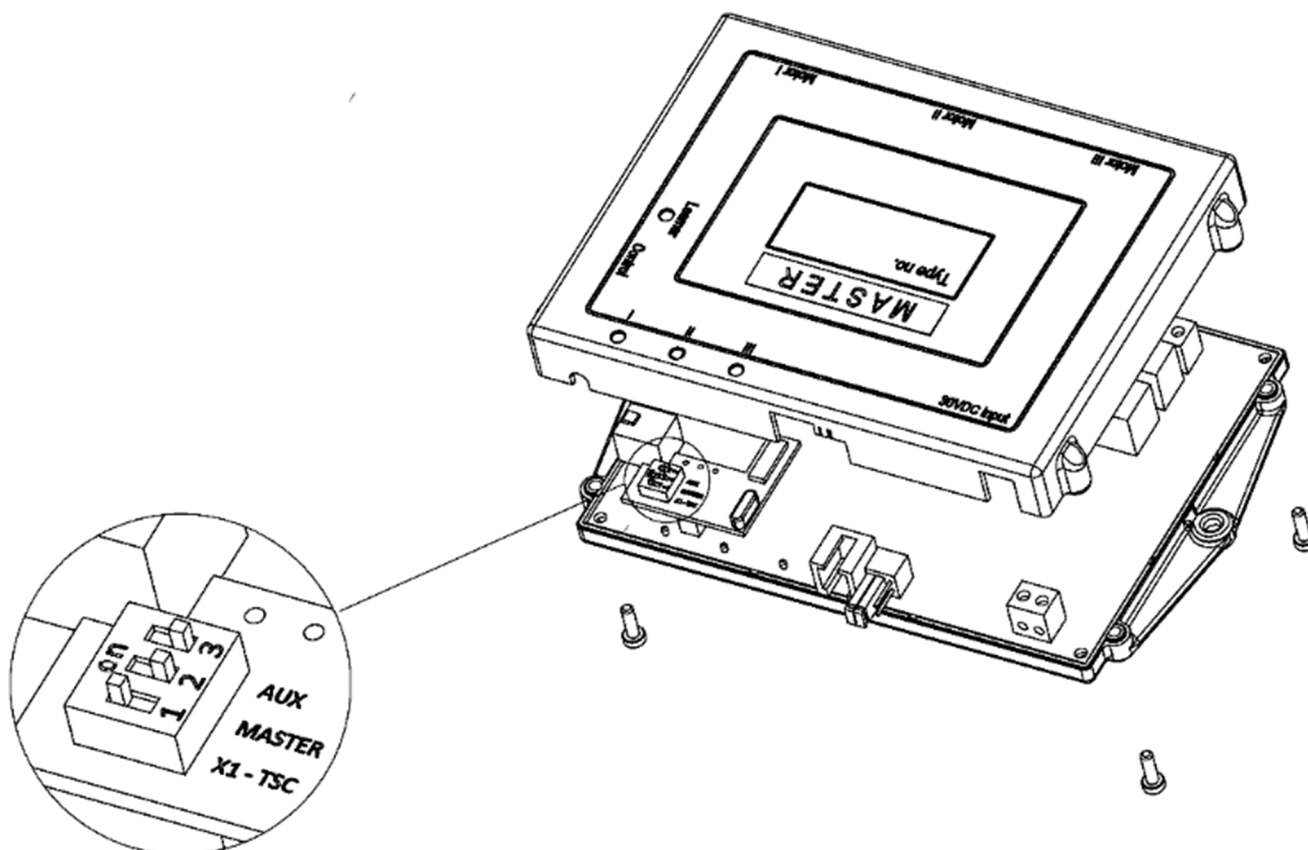

RF REMOTE EMITTER

The 7XPOWM can be controlled additional by a RF remote emitter.

- Up to 5 RF remote emitters can be coded to one MASTER box.
- Two mode options 'momentary' – press and hold or 'latching' – one press operation.
- Operation mode can be adjusted individually for each direction.

Coding

- a) Connect power to the MASTER box.
- b) Use a thin screw-driver or similar tool to probe squarely through the case to press the learner button and then release it (be careful to keep the tool perpendicular to the case surface).
- c) When all three LEDs turn on this indicates RF coding mode.
- d) Now press one button of the RF remote emitter, all three channel LEDs will flash five times and turn off.

The remote emitter handset is now coded to the MASTER box.

Resetting

- Press and hold the learner button – all three LEDs will flash five times and turn off – all previously coded RF remote emitters are removed from the MASTER box.

Operation mode

- Momentary mode: operates only when a button is being pressed. For most applications this is the safest mode. If the lifts are physically connected together then only use this mode.
- Latching mode – operates the full stroke when a button of the RF remote emitter is pressed.

These settings are specific to the RF emitter handset and have no affect on the manual control.

Note: The RF remote should not be used for height adjustable desks. Only use the manual control panel.

<i>Mode</i>	<i>Down movement</i>	<i>Up movement</i>
	<i>Jumper A</i>	<i>Jumper B</i>
<i>Momentary (default)</i>	<i>Set</i>	<i>Set</i>
<i>Latching</i>	<i>Removed</i>	<i>Removed</i>

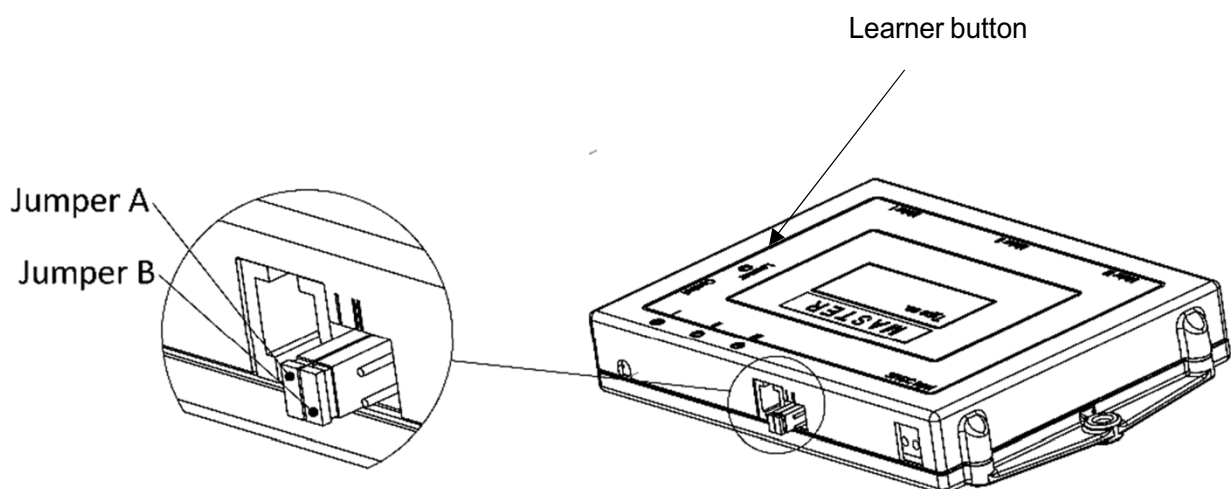

ELECTRONICALLY ADJUSTING THE STROKE LENGTH



You must only use the manual control panel to do this.

Setting a new bottom stop:

- a) Operate the manual control button until the lift is at the required bottom height and release.
- b) On the MASTER box push the learner button as previously described until all three LEDs come on and release.
- c) Now press the "Down" switch, all three channel LEDs will flash five times and turn off. The new bottom height is now set.

Setting a new top stop:

- a) Operate the manual control button until the lift is at the required top height and release.
- b) On the MASTER box push the learner button as previously described until all three LEDs come on and release.
- c) Now press the "up" switch, all three channel LEDs will flash five times and turn off. The new top height is now set.

To reset the factory settings - Bottom stop

Press the "Down" switch to send the lift in the downwards direction, keep pressing even after the bottom stop point is reached and then simultaneously press the learner button of the MASTER box once. All three channel LEDs will blink and the factory setting has been restored.

To reset the factory settings - Top stop

Press the "Up" switch to send the lift in the upwards direction, keep pressing even after the top stop point is reached and then simultaneously press the learner button of the MASTER box once. All three channel LEDs will blink and the factory setting has been restored.

Note: TS700C/TS1000C TV Lifts*

These models have an additional switch operated stroke adjustment. Please refer to the 'end stop' instructions that came with your TV lift. As an extra safety measure Venset suggest setting these end stops just beyond where you have set the electronic stroke adjustment. When you do this to the TV lifts you will effectively create a new 'factory set' lower* and upper stop position.

End stops - Installation & design - note 1:

The synchronization and resetting routine requires that the lifts can lower to their 'factory set' lower position. For the TV lifts you can create a new 'factory set' lower position (*see above) but it is not possible to do this for the Column lifts.

Practical meaning of note 1 regarding synchronisation and resetting:

TV lifts = Your installation may only need to accommodate the new stroke you have set.

Column lifts = Your installation should allow space for the columns to be fully lowered, i.e. to the factory setting like they came out of the box.

Venset recommends that all lifts should be removable for service, resetting or replacement.

End Stops - Safety - note 2:

TS700C/TS1000C have an electronic adjustment plus an additional switch operated adjustment (*see above). 501-X1 Column lifts only have electronic adjustment.

Reducing the stroke length by electronically adjusting the top and bottom stops should only be considered as a convenience system and should therefore not be relied upon where an unexpected full stroke of the lift(s) could cause damage or injury.

Practical meaning of note 2 regarding safety:

TV lifts = Safety can be increased by also setting the additional switch operated end stops.

Column lifts = Your installation is reliant only on electronic end stops.

SERVICE FAQ's

Overload protection

The 7XPOWM has overload protection built in. i.e. overload would be detected if the lift contacted a fixed object, such as an overhanging window sill.

When overloaded the 7XPOWM immediately reverses for around 2 seconds to unload the system. The overload protection works in both directions.

Cycle time protection

The MASTER box monitors the cycle time (active time in a given period of time) and will disable operation if the maximum cycle time has been exceeded.

A maximum cycle time of 50% within a period of 5 minutes is preprogrammed (it may run 2.5min continuously within 5min). When exceeding this limit, the MASTER box will disable operation and then activate itself again after 50% idle time (2.5min).

Asynchronous axis protection - (out of sync)

If the MASTER box detects height differences among the connected lifts, it will stop immediately to prevent future asynchronous movement.

All three channel LEDs will blink with 10Hz for 10 seconds indicating this situation. During these 10s, the system is blocked and operation is not possible. The reason for the asynchronous movement needs to be identified and removed.

Troubleshooting – (out of sync)

You will need to get the lifts all into their lowest position in order to perform a reset.

If the lifts are physically connected, such as by a table top or a large TV screen then the physical connection will likely need to be removed so that each lift can be lowered by individual connection to the PSU and manual control panel. Lower each leg one by one.

It may be possible to do this with the lifts physically connected to each other if it is done with a very small movement of each lift, alternating evenly from one leg to the next with a little movement each time until all are fully down.

LED indicator

LED mode	Channels	Description
OFF	1 - 3	Axis is disabled, no column connected
ON	1 - 3	Column detected and is just operating
BLINKING FAST	ALL	Asynchronous error detected
BLINKING SLOWLY (1Hz)	1 – 3	HALL sensor 1 or 2 is defect